

Modelica Implementation of the Skateboard Dynamics

Ivan I. Kosenko¹, Alexander S. Kuleshov²

¹ Moscow State University of Tourism and Service, Department of Engineering Mechanics, Glavnaya str., 99, Cherkizovo-1, Moscow reg., 141221, Russia

² Lomonosov Moscow State University, Department of Mechanics and Mathematics, Leninskie Gory, Main Building of MSU, Moscow, 119991, Russia

Abstract

In the present paper analysis and simulation are performed for a simplest model of a skateboard. We suppose that the rider control is absent during the motion. Equations of motion of the model are presented and their stability analysed in brief.

Modelica implementation of the skateboard dynamics is described as well. Its main featured outlined, and the verification procedures explained. It is pointed out the skateboard can behave in dynamical sense likewise the known example of the rattleback.

Keywords: skateboard; nonholonomic constraints; normal form; contact models, dynamical verification

1 Introduction

Nowadays the skateboarding, the art of riding on a skateboard, is one of the most popular sports. Nevertheless serious researches concerning dynamics and stability of a skateboard are almost absent. At the late 70th – early 80th of the last century Mont Hubbard [1, 2] proposed two mathematical models describing the motion of a skateboard with the rider. To derive equations of motion of the models he used the principal theorems of dynamics. In our paper we give the further development of the models proposed by Hubbard to have an additional possibility to verify the engineering solutions for this type of a vehicle.

Simultaneously to give the further move in field of the sportswear appliances development we created and verified a dynamical model of the skateboard. The model was developed on Modelica, and it is easy to improve it in different directions to be able to investigate the regular riding technique or the interesting tricks performed by the experts while the skateboarding shows.

The skateboard typically consists of a board, two trucks and four wheels, see Figure 1. The modern

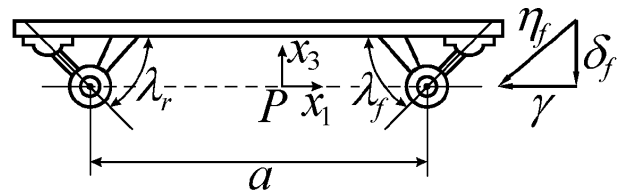

Figure 1: The Skateboard Side View

boards are usually from 78 to 83 cm long, 17 to 21 cm wide and 1 to 2 cm thick. The most essential elements of a skateboard are the trucks, connecting the axles to the board. Angular motion of both the front and rear axles is constrained to be about their respective non-horizontal pivot axes, thus causing a steering angle of the wheels whenever the axles are not parallel to the plane of the board, see Figure 2. The vehicle is steered by making use of this kinematic relationship between steering angles and tilt of the board. In addition, there is a torsional spring, which exerts a restoring torque between the wheelset and the board proportional to the tilt of the board with respect to the wheelset, Figure 3. We denote the stiffness of this spring by k_1 .

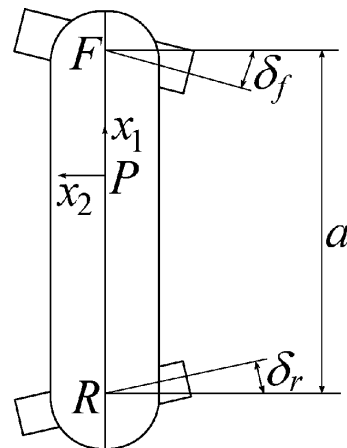

Figure 2: The Skateboard Top View

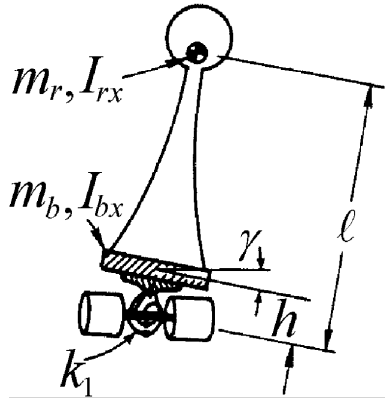

Figure 3: The Skateboard Front/Rear View

2 The Problem Formulation. Equations of Motion.

We assume that the rider, modeled as a rigid body, remains perpendicular with respect to the board. Therefore, when the board tilts through γ , the rider tilts through the same angle relative to the vertical. Let us introduce an inertial coordinate system $OXYZ$ in the ground plane. Let $FR = a$ is a distance between two axle centers F and R of a skateboard. The position of a line FR with respect to the $OXYZ$ -system is defined by X and Y coordinates of its center and by the angle θ between this line and the OX -axis, see Figure 4.

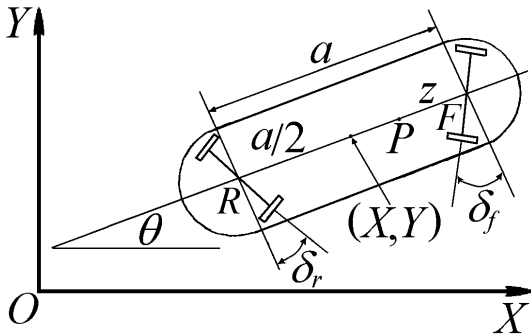

Figure 4: The Basic Coordinate Systems.

The tilt of the board causes the rotation of front wheels clockwise through δ_f and the rotation of rear wheels anticlockwise through δ_r , Figures 2, 4. The wheels of a skateboard are assumed to roll without lateral sliding. This condition is modeled by constraints, which may be shown to be nonholonomic

$$\begin{aligned} \dot{Y} \cos(\theta - \delta_f) - \dot{X} \sin(\theta - \delta_f) + \frac{1}{2} a \dot{\theta} \cos \delta_f &= 0, \\ \dot{Y} \cos(\theta + \delta_r) - \dot{X} \sin(\theta + \delta_r) - \frac{1}{2} a \dot{\theta} \cos \delta_r &= 0. \end{aligned} \quad (1)$$

Under these conditions velocities of a points F and R

will be directed horizontally and perpendicularly to the axles of wheels and there is a point P on the line FR which has zero lateral velocity. Its forward velocity we denote by u . It may be shown, that (see e. g. [1] – [6])

$$\begin{aligned} u &= -\frac{a \dot{\theta} \cos \delta_f \cos \delta_r}{\sin(\delta_f + \delta_r)}, \\ FP &= \frac{a \sin \delta_f \cos \delta_r}{\sin(\delta_f + \delta_r)}, \quad \dot{\theta} = -\frac{u \sin(\delta_f + \delta_r)}{a \cos \delta_f \cos \delta_r}. \end{aligned} \quad (2)$$

Using results obtained in [5, 6] we conclude that the steering angles δ_f and δ_r are related to the tilt of the board by the following equations

$$\tan \delta_f = \tan \lambda_f \sin \gamma, \quad \tan \delta_r = \tan \lambda_r \sin \gamma, \quad (3)$$

where λ_f and λ_r are the fixed angles which the front and rear axes make with the horizontal, Figure 1. Using constraints (3) we can rewrite equations (1) as follows

$$\begin{aligned} \dot{X} &= u \cos \theta + \frac{(\tan \lambda_f - \tan \lambda_r)}{2} u \sin \gamma \sin \theta, \\ \dot{Y} &= u \sin \theta - \frac{(\tan \lambda_f + \tan \lambda_r)}{2} u \sin \gamma \cos \theta. \end{aligned} \quad (4)$$

Expressions (2) become

$$FP = \frac{a \tan \lambda_f}{\tan \lambda_f + \tan \lambda_r}, \quad \dot{\theta} = -\frac{(\tan \lambda_f + \tan \lambda_r)}{a} u \sin \gamma. \quad (5)$$

Suppose that the board of the skateboard is located on the distance h above the line FR . The length of the board is also equal to a . The board center of mass is located in its center. As to the rider we suppose that the rider center of mass is not located above the board center of mass, but it is located over the central line of the board on a distance d from the front truck. Let l be the height of the rider center of mass above the point P . Other parameters for the problem are: m_b is the mass of the board, m_r is the mass of the rider; I_{bx} , I_{by} , I_{bz} are the principal central moments of inertia of the board; I_{rx} , I_{ry} , I_{rz} are the principal central moments of inertia of the rider. We introduce also the following parameters:

$$I_x = I_{bx} + I_{rx}, \quad I_y = I_{by} + I_{ry}, \quad I_z = I_{bz} + I_{rz}.$$

It can be proved, see [5], that the variables u and γ satisfy the following differential equations

$$\begin{aligned} (A + (C - 2D) \sin^2 \gamma + K \sin^4 \gamma) \dot{u} + \\ (C - 3D + 3K \sin^2 \gamma) u \dot{\gamma} \sin \gamma \cos \gamma + \\ B (\ddot{\gamma} \cos \gamma - \dot{\gamma}^2 \sin \gamma) \sin \gamma &= 0, \\ E \ddot{\gamma} + (D - K \sin^2 \gamma) u^2 \sin \gamma \cos \gamma + \\ k_1 \gamma - (m_b h + m_r l) g \sin \gamma + \\ B (\dot{u} \sin \gamma + u \dot{\gamma} \cos \gamma) \cos \gamma &= 0. \end{aligned} \quad (6)$$

Here A, \dots, E, K are functions of the parameters, namely

$$\begin{aligned}
 A &= m_b + m_r, \\
 E &= I_x + m_b h^2 + m_r l^2, \\
 B &= \frac{m_b h}{2} (\tan \lambda_f - \tan \lambda_r) + \\
 &\quad \frac{m_r l}{a} ((a-d) \tan \lambda_f - d \tan \lambda_r), \\
 C &= \frac{m_b}{4} (\tan \lambda_f - \tan \lambda_r)^2 + \\
 &\quad \frac{I_z}{a^2} (\tan \lambda_f + \tan \lambda_r)^2 + \\
 &\quad \frac{m_r}{a^2} ((a-d) \tan \lambda_f - d \tan \lambda_r)^2, \\
 D &= \frac{(\tan \lambda_f + \tan \lambda_r)}{a} (m_b h + m_r l), \\
 K &= \frac{(\tan \lambda_f + \tan \lambda_r)^2}{a^2} (I_y + m_b h^2 + m_r l^2 - I_z).
 \end{aligned}$$

Thus, equations (4–6) form the closed DAE system for the skateboard motion.

3 Stability of the Skateboard Straight-Line Motion

Equations (6) have a particular solution

$$u = u_0 = \text{const}, \quad \gamma = 0, \quad (7)$$

which corresponds to a uniform straight-line motion of the skateboard. The stability conditions of this particular solution have the following form [1]-[6]:

$$B u_0 > 0, \quad D u_0^2 + k_1 - (m_b h + m_r l) g > 0. \quad (8)$$

From the first condition of (8) we can conclude that the stability of motion (7) depends on its direction. If one direction of motion is stable the opposite direction is necessary unstable. Such a behavior is peculiar to many nonholonomic systems. First of all, we can mention here the classical problem the rattleback motion (aka wobblestone or celtic stone, see e. g. [7]-[9]). In this problem the stability of permanent rotations of a rattleback also depends on the direction of rotation. Suppose that the coefficient B is positive, $B > 0$. Then for $u_0 > 0$ the skateboard moves in “stable” direction, and for $u_0 < 0$ it moves in “unstable” direction. When $u_0 = 0$ the skateboard is in equilibrium position on the plane. The necessary and sufficient condition for stability of this equilibrium have a form [1]-[6]:

$$k_1 - (m_b h + m_r l) g > 0. \quad (9)$$

Assuming that condition (9) holds, let us consider the behavior of the system near the equilibrium position. Solving equations (6) with respect to \dot{u} and $\dot{\gamma}$ and assuming that u, γ and $\dot{\gamma}$ are small, we can write equations of perturbed motion taking into account the terms which are quadratic in u, γ and $\dot{\gamma}$ as follows

$$\dot{u} = \frac{B \Omega^2}{A} \gamma^2, \quad \ddot{\gamma} + \Omega^2 \gamma = -\frac{B u \dot{\gamma}}{E}, \quad (10)$$

where we introduce the following notation

$$\Omega^2 = \frac{k_1 - (m_b h + m_r l) g}{E}.$$

Note, that the linear terms in the second equation of the system (10) have a form which corresponds to a normal oscillations. For investigation of nonlinear system (10) we reduce it to a normal form [10]. To obtain the normal form of the system (10) first of all we make a change of variables and introduce two complex-conjugate variables z_1 and z_2 such that

$$\gamma = \frac{z_1 - z_2}{2i}, \quad \dot{\gamma} = \frac{z_1 + z_2}{2} \Omega, \quad u = z_3.$$

In variables $z_k, k = 1, 2, 3$ the linear part of the system (10) has a diagonal form and the derivation of its normal form reduces to separating of resonant terms from the nonlinearities in the right-hand sides of the transformed system (10). Finally, the normal form of the system (10) may be written as follows

$$\begin{aligned}
 \dot{z}_1 &= i \Omega z_1 - \frac{B}{2E} z_1 z_3, \\
 \dot{z}_2 &= -i \Omega z_2 - \frac{B}{2E} z_2 z_3, \\
 \dot{z}_3 &= \frac{B \Omega^2}{2A} z_1 z_2.
 \end{aligned}$$

Introducing real polar coordinates according to the formulae

$$\begin{aligned}
 z_1 &= \rho_1 (\cos \sigma + i \sin \sigma), \\
 z_2 &= \rho_1 (\cos \sigma - i \sin \sigma), \\
 z_3 &= \rho_2
 \end{aligned}$$

we obtain from the system (10) the normalized system of equations of perturbed motion which is then split into two independent subsystems:

$$\dot{\rho}_1 = -\frac{B}{2E} \rho_1 \rho_2, \quad \dot{\rho}_2 = \frac{B \Omega^2}{2A} \rho_1^2, \quad (11)$$

$$\dot{\sigma} = \Omega. \quad (12)$$

Terms of order higher than the second in (11) and those higher than the first in $\rho_k, k = 1, 2$ in (12) have been omitted here.

In the ε -neighborhood of the equilibrium position the right-hand sides of equations (11) and (12) differ from the respective right-hand sides of the exact equations of perturbed motion by quantities of order ε^3 and ε^2 respectively. The solutions of the exact equations are approximated by the solutions of system (11–12) with an error of ε^2 for ρ_1 , ρ_2 and of order ε for σ over time interval of order $1/\varepsilon$. Restricting the calculations to this accuracy, we will consider the approximate system (11–12) instead of the complete equations of perturbed motion.

Equation (12) is immediately integrable, and we obtain

$$\sigma = \Omega t + \sigma_0.$$

System (11) describes the evolution of the amplitude ρ_1 of the board oscillations and also the evolution of the velocity ρ_2 of a the skateboard straight-line motion. One can see that this system has the first integral

$$E\rho_1^2 + \frac{A}{\Omega^2}\rho_2^2 = An_1^2, \quad (13)$$

where n_1 is a constant, specified by initial conditions. We will use this integral for solving of the system (11) and for finding the variables ρ_1 and ρ_2 as functions of time: $\rho_1 = \rho_1(t)$, $\rho_2 = \rho_2(t)$. Expressing ρ_2^2 from the integral (13) and substitute it to the second equation of the system (11) we get

$$\dot{\rho}_2 = \frac{B}{2E} (\Omega^2 n_1^2 - \rho_2^2). \quad (14)$$

The general solution of equation (14) has the following form:

$$\rho_2(t) = \frac{\Omega n_1 \left(1 - n_2 \exp\left(-\frac{B\Omega n_1}{E}t\right)\right)}{\left(1 + n_2 \exp\left(-\frac{B\Omega n_1}{E}t\right)\right)}, \quad (15)$$

where n_2 is a nonnegative arbitrary constant. Now, using the integral (13), we can find the explicit form of the function $\rho_1(t)$ in the following way

$$\rho_1(t) = 2n_1 \sqrt{\frac{An_2}{E}} \frac{\exp\left(-\frac{B\Omega n_1}{2E}t\right)}{1 + n_2 \exp\left(-\frac{B\Omega n_1}{E}t\right)}. \quad (16)$$

Let us consider the properties of the solutions (15), (16) of system (11) and their relations to the properties of the skateboard motion. System (11) has an equilibrium position

$$\rho_1 = 0, \quad \rho_2 = \Omega n_1. \quad (17)$$

These particular solutions can be obtained from general functions (15–16) if we suppose in that functions

$n_2 = 0$. An arbitrary constant n_1 can be both positive and negative. The positive values of this constant correspond to the skateboard straight-line motions with small velocity in “stable” direction and the negative ones do in “unstable” direction. Indeed, if we linearize equations (11) near the equilibrium position (17) we get

$$\dot{\rho}_1 = -\frac{B}{2E}\Omega n_1 \rho_1, \quad \dot{\rho}_2 = 0.$$

Thus, for $n_1 > 0$ the equilibrium position (17) is stable and for $n_1 < 0$ it is unstable.

Evolution of the functions ρ_1 and ρ_2 gives the complete description of behavior of a skateboard with small velocities. Let us suppose, that at initial instant the system is near the stable equilibrium position ($n_1 > 0$) and $\rho_2(0) \geq 0$, i. e. $n_2 \leq 1$. The case of $n_1 > 0, n_2 > 1$ is similar to the case of $n_1 < 0, n_2 < 1$, which will be investigated below. These initial conditions correspond to the situation correspond to the skateboard to take the small velocity

$$\rho_2(0) = \Omega n_1 \frac{1 - n_2}{1 + n_2}$$

in the “stable” direction at initial instant. Then in the course of time the “amplitude” ρ_1 of the board oscillations decreases monotonically from its initial value

$$\rho_1(0) = \frac{2n_1}{1 + n_2} \sqrt{\frac{An_2}{E}}$$

to zero, while the velocity of a skateboard ρ_2 increases in absolute value. In the limit the skateboard moves in stable direction with a constant velocity Ωn_1 , see Figure 5–6.

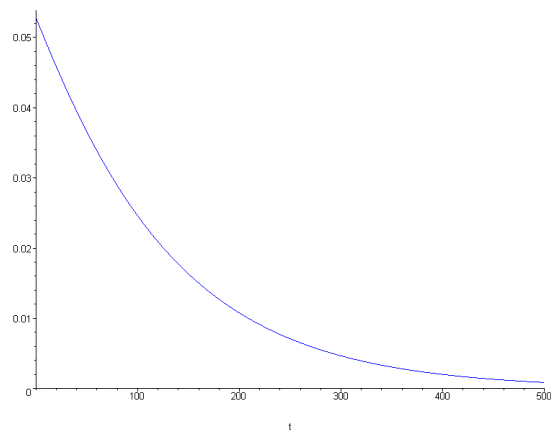

Figure 5: Evolution of the Amplitude ρ_1 of the Board Oscillations in Time for the Case $n_1 > 0, n_2 \leq 1$.

Suppose now that at initial instant the system is near the unstable equilibrium position $n_1 < 0$. Suppose

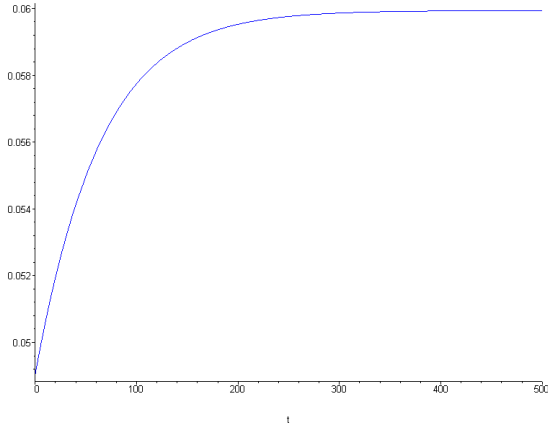

Figure 6: Evolution of the "Velocity" ρ_2 of the Skateboard in Time for the Case $n_1 > 0, n_2 \leq 1$.

again, that at initial instant $n_2 < 1$, i. e. $\rho_2(0) < 0$. The case $n_1 < 0, n_2 > 1$ is similar to the case $n_1 > 0, n_2 < 1$ which was considered above. These initial conditions correspond to the situation if at initial instant the skateboard takes the small velocity

$$\rho_2(0) = \Omega n_1 \frac{1 - n_2}{1 + n_2}$$

in "unstable" direction. In this case the limit of the system motions is the same as for $\rho_2(0) \geq 0$ but the evolution of the motion is entirely different. For

$$0 < t < t_* = \frac{E \ln(n_2)}{B\Omega n_1}$$

the absolute value of the oscillation "amplitude" ρ_1 increases monotonically and the skateboard moves in unstable direction with decreasing velocity. At the instant $t = t_*$ the velocity vanishes and the oscillation "amplitude" ρ_1 reaches its maximum absolute value

$$\rho_1(t_*) = n_1 \sqrt{\frac{A}{E}}.$$

When $t > t_*$ the skateboard already moves in stable direction with an increasing absolute value of its velocity and the oscillation amplitude decreases monotonically. Thus when $\rho_2(0) < 0$ during the time of evolution of the motion a change in the direction of motion of the skateboard occurs, see Figure 7–8. The similar nonlinear effects, like the change of the motion direction, were observed earlier in other problems of nonholonomic mechanics, for example in a classical problem of dynamics of the rattleback [7]-[9]. Thus, we describe here the basic features of the simplest skateboard model dynamics, proposed in [1, 2] and developed by us.

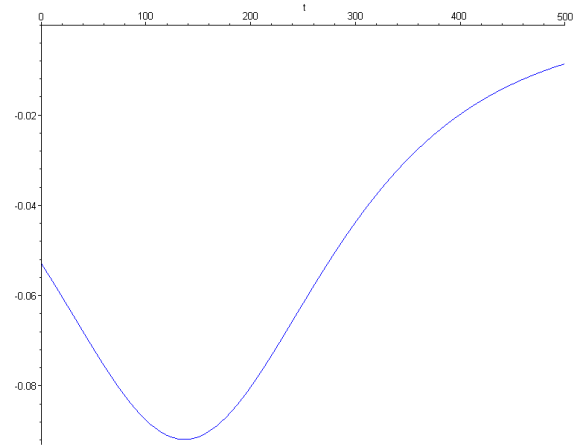

Figure 7: Evolution of the Amplitude ρ_1 of the Board Oscillations in Time for the Case $n_1 < 0, n_2 \leq 1$.

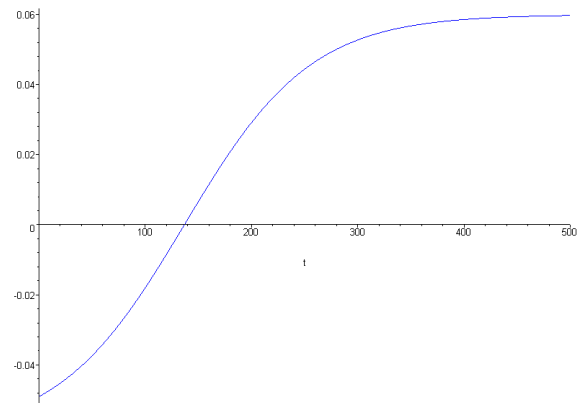

Figure 8: Evolution of the "Velocity" ρ_2 of the Skateboard in Time for the Case $n_1 < 0, n_2 \leq 1$.

4 Implementation and Experimental Validation

Evidently an analytic modeling and a numeric simulation may be useful to predict the dynamical properties of the sports equipment, the skateboard in our case. To verify a possibility of the behavior described above, i. e. an asymmetry property of stability depending on the rider relocation on the board, an attempt was undertaken to create the model of this device, see Figure 9.

To achieve the goal announced we used an approach and components applied earlier to the one else sports appliance: the snakeboard [11]. However, we have a serious differences with the snakeboard model now. First, we used a spheroids of different shapes instead of ideal disks. That seems more natural and allows to consider as a wheels more plausible models of the elastic bodies rolling in future. The main current dif-

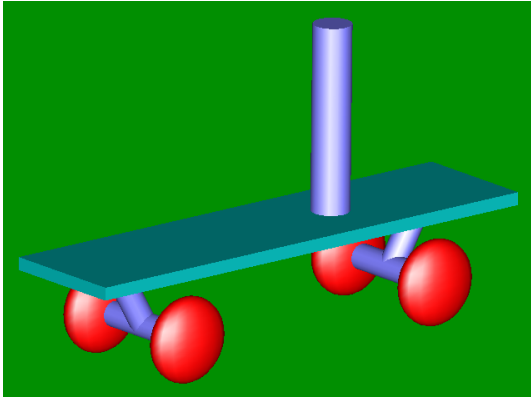

Figure 9: The Skateboard Model Animation

ference is that we applied the Hertz model and its volumetric modification for the contact of the wheel and the floor [12]. This made it possible to avoid entirely an application of the compliances artificially introduced to the skateboard model in [11].

The wheelset model, see in Figure 10 its visual model, thus equipped by the objects of a simple revolute joint class `FixedJoint` instead of the joint model `SpringJoint` with elastic compliance along its axis. The joint connects the wheel with the shaft of the wheelset axis.

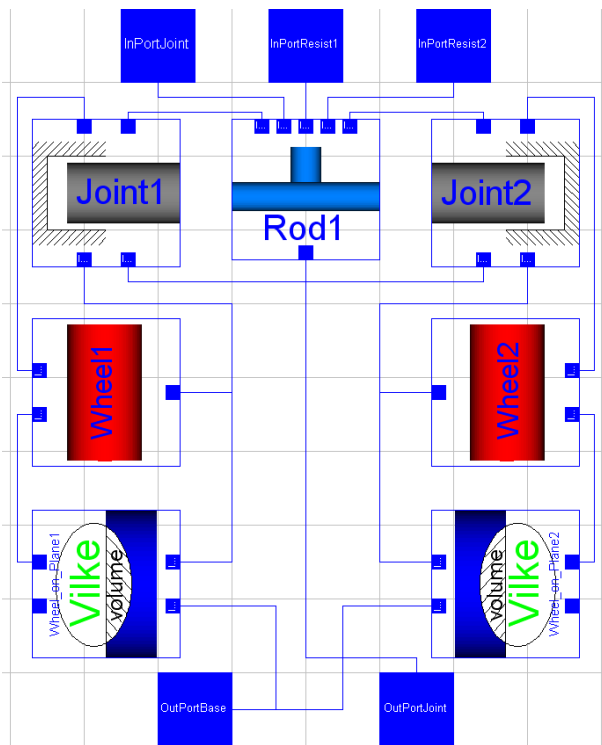

Figure 10: The Wheelset Visual Model

We saw above that in difference with the skateboard an axis of the joint connection of the board and the

wheelset is not vertical and allows the rider an effective possibility to maneuver along the road. Besides to ensure the stable riding the manufacturers frequently equip their skateboards by an elastic connections the wheelset axle and the board. Such a construct includes two springs of a high stiffness. An example of the so-called "Seismic" truck invented by D. Gesmer and M. Haug [13] see in Figure 11. The whole skateboard visual model including the spring elements is shown in Figure 12.



Figure 11: The Truck with Springs

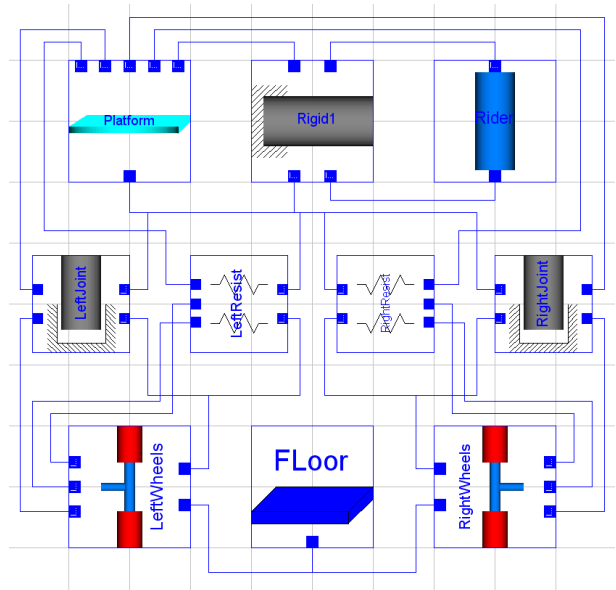

Figure 12: The Skateboard Visual Model

The visual model of the spring connection see in Figure 13. Here the side *A* of a particular spring elements, `Spring1` and `Spring2`, is connected with the wheelset axle model, while the *B*-sides of these objects merge to one point producing one total effort. Further the model `Spring` is a usual spatial spring element resisting both the compression and the stretch. Its Modelica code has the following easy to read form:

```

model Spring
  extends Constraint;
  //undeformed spring length
  parameter SI.Length l;
  //spring stiffness
  parameter Real c;
  //fixed point on Body A
  parameter SI.Position[3] rA ;
  //fixed point on Body B
  parameter SI.Position[3] rB;
  //fixed point on Body A in abs. syst.
  SI.Position[3] RA;
  //fixed point on Body B in abs. syst.
  SI.Position[3] RB;
  SI.Length[3] RAB;
  SI.Length deltaL;
equation
  RA = InPortA.r + InPortA.T*rA;
  RB = InPortB.r + InPortB.T*rB;
  OutPortA.P = RA;
  OutPortB.P = RB;
  RAB = RB - RA;
  deltaL = sqrt((RAB -
    l*RAB/sqrt(RAB*RAB)) *
    (RAB - l*RAB/sqrt(RAB*RAB)));
  OutPortB.F = -c*deltaL*RAB/
    sqrt(RAB*RAB);
  OutPortB.M = zeros(3);
end Spring;
  
```

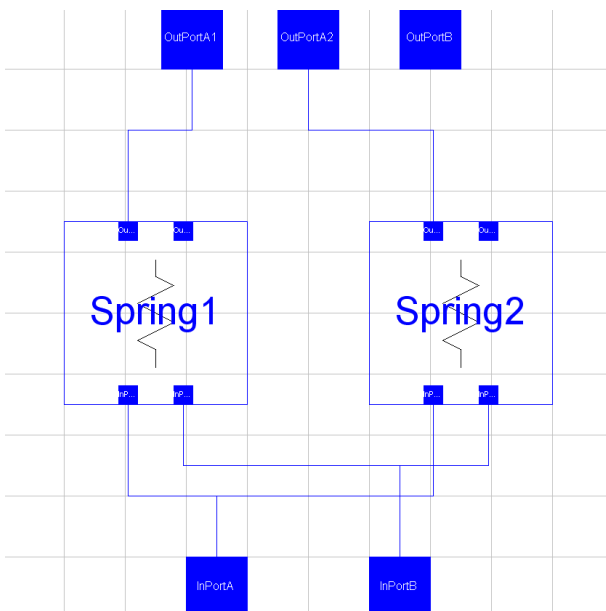

Figure 13: The Spring Connection Visual Model

Let us continue a description of the skateboard visual model in Figure 12. It is quite natural for the rider to be included into the vehicle dynamics. In our case the rider reduced simply to the cylinder standing perpendicular to the board top surface and being connected

to it rigidly, by the constraint of the class Rigid. A various numeric experiments performed with the skateboard model under consideration. In particular, to verify the dynamic effect of the stability of motion asymmetry, being similar to the stability asymmetry of the rattleback rotation, the cylinder playing a role of the rider motionlessly standing on the board was shifted to the right away from the board masscenter. In this case according to results outlined above if one pushes the whole skateboard to the right then the skateboard will keep this motion all the time of simulation. Otherwise, if one directs an initial skateboard velocity to the left then soon the skateboard would stop its translatory motion and then will start it to the right direction thus demonstrating instability of the left translatory motions, see the board masscenter velocity x -coordinate depending on the time in Figure 14 and the corresponding 2D-plot of the board masscenter x -coordinate itself in Figure 15.

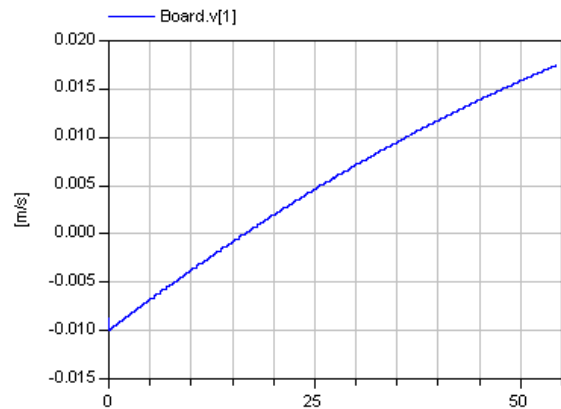

Figure 14: The Skateboard Velocity

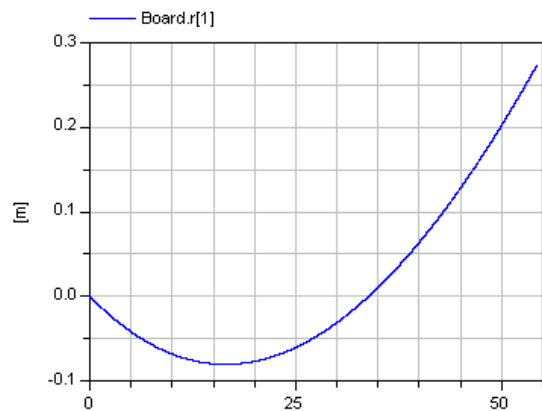

Figure 15: The Skateboard Position

Remark that the skateboard model built up turned out to be quite effective dynamic “toy” allowing to sim-

ulate the skateboard roll overs, tumbling, jumps, and bouncing over the road. It is clear to simulate a control of such motion the rider model has to be far more complicated.

5 Conclusions

An analytic analysis and numeric experimentation performed on the skateboard dynamics allow us to have simultaneously several conclusions:

- The analytic analysis results showing acceptable consistence with the numeric simulations of the models created using the physical oriented approach still remains an effective tool to investigate the skateboard dynamics.
- On the other hand the model itself can be verified reliably enough using the proper constructed analytical tools.
- Modelica turned out to be useful instrument in field of sporting and more wider in field of biomechanical applications.

And finally the nearest plans for the future work are about to investigate the complicated types of the skateboard motion including in particular the jumps.

6 Acknowledgement

The paper was prepared with partial support of Russian Foundation for Basic Research, projects 05-01-00308-a, 05-08-65470, 05-01-00454, 07-01-00290, SS-6667.2006.1.

References

- [1] Hubbard M., Lateral Dynamics and Stability of the Skateboard // *Journal of Applied Mechanics*, 1979, Vol. 46, pp. 931–936.
- [2] Hubbard M., Human Control of the Skateboard // *Journal of Biomechanics*, 1980, Vol. 13, pp. 745–754.
- [3] Kuleshov A. S., Mathematical Model of the Skateboard // *Proceedings of XXIV Int. Symp. on Biomechanics in Sports*, Salzburg, Austria, 2006, Vol. 2, pp. 715–719.
- [4] Kuleshov A. S., Mathematical Model of a Skateboard with One Degree of Freedom // *Doklady Physics*, 2007, Vol. 52, No. 5, pp. 283–286.
- [5] Kremnev A. V., Kuleshov A. S., Nonlinear Dynamics and Stability of a Simplified Skateboard Model, 2007.
<http://akule.pisem.net/Kuleshov2.pdf>
- [6] Österling A. E. MAS 3030. On the Skateboard, Kinematics and Dynamics. School of Mathematical Sciences. University of Exeter. UK. 2004.
<http://akule.pisem.net/theSkateboard.pdf>
- [7] Lindberg R. E., Longman R. W. On the Dynamic Behavior of the Wobblestone // *Acta Mechanica*, 1983, Vol. 49, pp. 81–94.
- [8] Bondi H. The Rigid Body Dynamics of Unidirectional Spin // *Proceedings of the Royal Society of London, Series A*, 1986, Vol. 405, pp. 265–274.
- [9] Garcia A., Hubbard M. Spin Reversal of the Rattleback: Theory and Experiment // *Proceedings of the Royal Society of London, Series A*, 1988, Vol. 418, pp. 165–197.
- [10] Bruno A. D. *Local Method in Nonlinear Differential Equation* — Springer-Verlag: Berlin, 1989.
- [11] Kosenko I. I., Loginova M. S., Obraztsov Ya. P., Stavrovskaya M.S. Multibody Systems Dynamics: Modelica Implementation and Bond Graph Representation // *Proceedings of the 5th International Modelica Conference*, arsenal research, Vienna, Austria, September 4–5, 2006, pp. 213–223.
- [12] Kosenko I. I., Alexandrov E. B. Implementation of the Hertz Contact Model and Its Volumetric Modification on Modelica // Submitted to *Modelica'2008 Conference*.
- [13] Gesmer D., Haug M. Skateboard truck assembly. 1993.
<http://www.freepatentsonline.com/5263725.pdf>